

BLACKMER PARTS LIST

PUMP MODELS: XF1C, XB1C, XF1PC, XB1PC

and Discontinued Models XF1(P)B, XB1(P)B, XF1(P)A, XB1(P)A

Keep with Instructions 101-A00 for Installation, Operation and Maintenance

961221

Page 1 of 2

PARTS LIST

101-A01

Section
Effective
Replaces

101
September 2009
September 2007

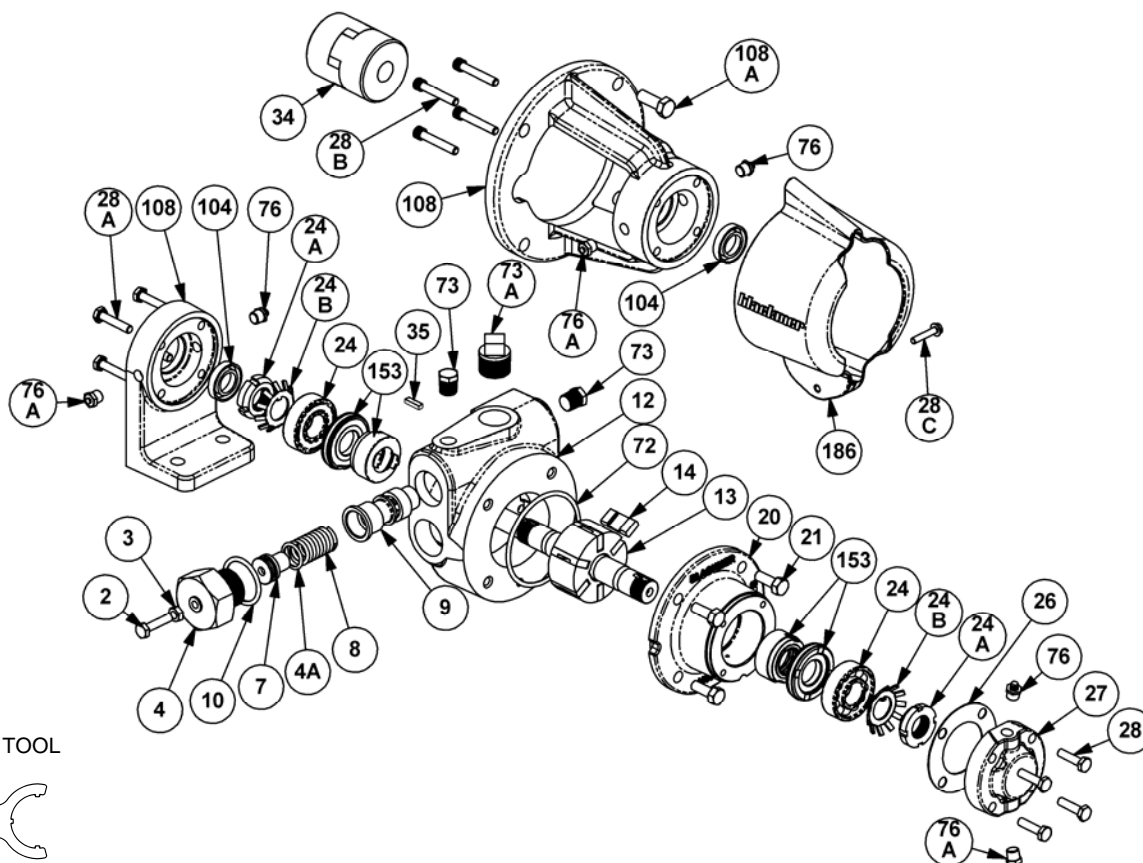

LOCKNUT TOOL

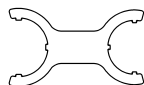

Ref. No.	Description	Parts per Pump	Part No.	Ref. No.	Description	Parts per Pump	Part No.
2	Adjusting Screw – Relief Valve (R/V)	1	432901	28A**	Bracket Mounting Screws	4	920090
3	Locknut – Adjusting Screw	1	922811	28B**	Bracket Mounting Screws	4	920101
4	Cover – R/V	1	412901	28C	Guard Screw	1	920026
4A	O-Ring – Spring Guide (FKM)	1	702029	34	Coupling Half – Pump	1	906150
7	Spring Guide – R/V	1	422901		Coupling Half – Motor (56C)		906151
8	Spring – R/V (66 - 125 psi) (Std.)	1	472905		Coupling Half – Motor (143-145TC/184C)		906147
	Spring – R/V (35 - 65 psi)		472903		Coupling Spider		906155
9	Valve – R/V (Std.)	1	452901	35	Key – Shaft, Square	1	^{1,2} 909152
10	O-Ring – R/V Cover (FKM)	1	701969	72	O-Ring – Head (FKM) (Std.)	1	¹ 711930
12**	Cylinder – XF1, XB1	1	022914	73	Gage Plug (1/4")	2	908198
	Cylinder – XF1P, XB1P		022915	73A**	Gage Plug (3/4")	1	908225
13	Rotor & Shaft Assembly, Six Vane (Includes Ref. Nos. 24A & 24B)	1	³ 262907	76	Grease Fitting	2	317815
14	Vane – Duravane (Std.)	4, 6	^{1,4} 092913	76A	Grease Relief Fitting	2	701992
20**	Head	1	032905	104	Grease Seal	1	¹ 331934
21	Capscrews – Head	4	920178	108**	Mounting Bracket – XB1B/C & XB1PB/C	1	832913
24	Ball Bearing	2	¹ 903405		Mounting Bracket – XF1B/C & XF1PB/C		832912
24A	Locknut – Bearing	2	903531	108A	Capscrew – Bracket	4	920331
24B	Lockwasher – Bearing	2	¹ 903532	108B	Bracket (C-faced footed)		SEE PAGE 2
26**	Gasket – Bearing Cover	1	¹ 383075	186	Guard	1	804120
27**	Bearing Cover	1	043071		Tool - Locknut		903090
28**	Capscrews – Bearing Cover	8	920080		Kit – Maintenance (4-Vane)		898960
					Kit – Maintenance (6-Vane)		898995

¹ Included in Maintenance Kit ² Maintenance Kit also includes Woodruff Key 909126 used previously

³ Discontinued 'B' and 'A' models shipped with a 4-vane rotor. The 6-vane rotor is interchangeable if slotted vanes (pn 092913) are used.

⁴ The current slotted vanes (pn 092913) may be used in either the 6-vane or 4-vane rotors. The discontinued solid vanes may be used in the 4-vane rotors ONLY. Always install the vanes with the slot facing the direction of rotation.

** To fit the XF1(P)A, XB1(P)A use: Ref. No. 12-022902/022911 respectively, Ref. No. 20-032902, Ref. No. 26-382901, Ref. No. 27-042901, Ref. No. 28-920203, Ref. No. 28A & B-920230, Ref No. 73A-908198 and Ref. No.108-832901/832905 respectively.

MECHANICAL SEAL

Ref. No.	Part Name	Parts Per Pump	Part No.
153	Mechanical Seal Assembly	2	¹ 332921
	Hardened Steel Stationary Seat, Carbon Rotating Seal Face, FKM O-Rings (SVCV) (std)		332924
	Hardened Steel Stationary Seat with FKM O-Ring, Carbon Rotating Seal Face with PTFE Seal Ring (SVCT)		
153A	Jacket Assembly	2	332922
153B	Stationary Seat – Hardened Steel	2	332901
153D	O-Ring – Stationary (FKM)	2	711908
153F	Rotating Seal Face – Carbon	2	332902
	Rotating Seal Face – Carbon & PTFE		332900
153G	O-Ring – Rotating (FKM)	2	711942
	Seal Ring – Rotating (PTFE)		**
153N	Seal Backup Ring (Steel)	2	332906

¹ Included in Maintenance Kit

**PTFE Rotating Seal Ring is not available as a separate part.

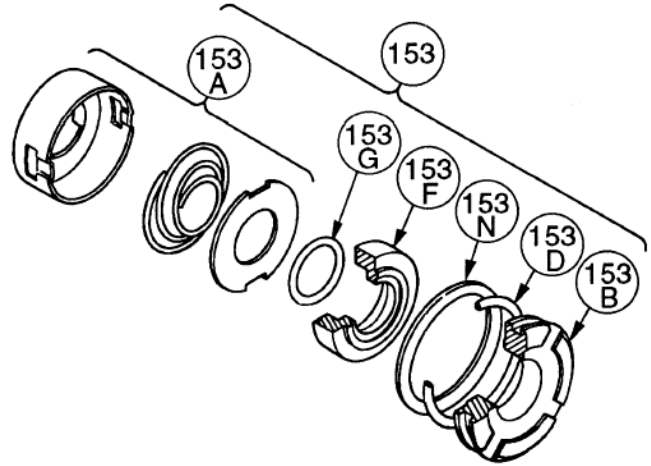

MOUNTING BRACKET

Ref. No.	Part Name	Parts Per Pump	Part No.
108B	Bracket (C-faced footed)	1	833000

