

BLACKMER POWER PUMPS

INSTALLATION OPERATION AND MAINTENANCE INSTRUCTIONS

ProVane® Models: PV, PVS

Section	111
Effective	August 2005
Replaces	March 2005

Patent Protected by U.S. Patent 6030191, other U.S. and Foreign Patents Pending.

TABLE OF CONTENTS	Page
General Safety Data.....	1-2
PUMP DATA	
Initial Pump Start Up Information.....	2
Technical Data	2
INSTALLATION	
Pre-Installation Cleaning	3
Location and Piping.....	3
Mounting	4
Coupling Alignment	4
Liner Intake & Discharge Identification	4
Pump Rotation.....	4
To Reverse Pump Flow Direction.....	4
Check Valves	4
OPERATION	
Pre-Start Up Check List.....	5
Start Up Procedures.....	5
Running the Pump in Reverse.....	5
Flushing the Pump	6
Pump Relief Valve.....	6
MAINTENANCE	
Torque Table.....	7
Lubrication.....	7
Strainers.....	7
Vane Replacement.....	7-8
Pump Disassembly	8
Parts Replacement.....	9
Pump Assembly	9
TROUBLE SHOOTING	13

ONLY Pump models listed below are covered in this Manual

Cylinder Type Models	Material	Parts List
PV6A, PV8A	Ductile Iron	111-A01
PVS6A, PVS8A	Stainless Steel	111-A06
Single Liner Models	Material	Parts List
PV10A, PV15A	Ductile Iron	111-A02
PVS10A, PVS15A	Stainless Steel	111-A07
PV20A, PV30A PV40A, PV50A	Ductile Iron	111-A03
PVS20A, PVS30A PVS40A, PVS50A	Stainless Steel	111-A08
Tandem Liner Models	Material	Parts List
PV80A, PV100A	Ductile Iron	111-A04
PVS80A, PVS100A	Stainless Steel	111-A09
PV150A, PV200A	Ductile Iron	111-A05
PVS150A, PVS200A	Stainless Steel	111-A10

Blackmer manuals and parts lists may be obtained from Blackmer's website (www.blackmer.com) or by contacting Blackmer Customer Service.

Numbers in parentheses following individual parts indicate reference numbers on Blackmer Part Lists.

SAFETY DATA



This is a SAFETY ALERT SYMBOL.

When you see this symbol on the product, or in the manual, look for one of the following signal words and be alert to the potential for personal injury, death or major property damage



Warns of hazards that WILL cause serious personal injury, death or major property damage.



Warns of hazards that CAN cause serious personal injury, death or major property damage.



Warns of hazards that CAN cause personal injury or property damage.

NOTICE:

Indicates special instructions which are very important and must be followed.

NOTICE:

Blackmer Pumps **MUST** only be installed in systems, which have been designed by qualified engineering personnel. The system **MUST** conform to all applicable local and national regulations and safety standards.

This manual is intended to assist in the installation and operation of the Blackmer ProVane pumps, and **MUST** be kept with the pump.

Pump service shall be performed by qualified technicians **ONLY**. Service shall conform to all applicable local and national regulations and safety standards.

Thoroughly review this manual, all instructions and hazard warnings, **BEFORE** performing any work on the pump.

Maintain **ALL** system and pump operation and hazard warning decals.

SAFETY DATA

⚠WARNING



Hazardous machinery can cause serious personal injury.

FAILURE TO DISCONNECT AND LOCKOUT ELECTRICAL POWER OR ENGINE DRIVE BEFORE ATTEMPTING MAINTENANCE CAN CAUSE SEVERE PERSONAL INJURY OR DEATH

⚠WARNING



Hazardous voltage. Can shock, burn or cause death.

FAILURE TO DISCONNECT AND LOCKOUT ELECTRICAL POWER BEFORE ATTEMPTING MAINTENANCE CAN CAUSE SHOCK, BURNS OR DEATH

⚠WARNING



Hazardous or toxic fluids can cause serious injury.

IF PUMPING HAZARDOUS OR TOXIC FLUIDS, SYSTEM MUST BE FLUSHED AND DECONTAMINATED, INSIDE AND OUT, PRIOR TO PERFORMING SERVICE OR MAINTENANCE

⚠WARNING



Hazardous pressure can cause personal injury or property damage

DISCONNECTING FLUID OR PRESSURE CONTAINMENT COMPONENTS DURING PUMP OPERATION CAN CAUSE SERIOUS PERSONAL INJURY, DEATH OR MAJOR PROPERTY DAMAGE

⚠WARNING



Do not operate without guard in place

OPERATION WITHOUT GUARDS IN PLACE CAN CAUSE SERIOUS PERSONAL INJURY, MAJOR PROPERTY DAMAGE, OR DEATH.

⚠WARNING



Hazardous pressure can cause personal injury or property damage

FAILURE TO RELIEVE SYSTEM PRESSURE PRIOR TO PERFORMING PUMP SERVICE OR MAINTENANCE CAN CAUSE PERSONAL INJURY OR PROPERTY DAMAGE.

PUMP DATA

PUMP IDENTIFICATION

A pump Identification tag, containing the pump serial number, I.D. number, and model designation, is attached to each pump. The data from this tag should be recorded and filed for future reference. If replacement parts are needed, or if information pertaining to the pump is required, this data must be furnished to a Blackmer representative.

INITIAL PUMP START UP INFORMATION

Model No.:	_____
Serial No.:	_____
ID No.:	_____
Date of Installation:	_____
Inlet Gauge Reading:	_____
Discharge Gauge Reading:	_____
Flow Rate:	_____

TECHNICAL DATA

Technical Data is for standard materials of construction. Consult Blackmer Material Specs for optional materials of construction

Pump Size	6A, 8A	10A, 15A, 20A, 30A, 40A, 50A,	80A, 100A	150A, 200A
Maximum Pump Speed	3600 RPM	1750 RPM	1750 RPM	1150 RPM
Flow Rate at Max. Pump speed	6-8 GPM (23-30 LPM)	10-50 GPM (38-189 LPM)	80-100 GPM (303-379 LPM)	150-200 GPM (568-757 LPM)
Maximum Operating Temperature	240°F (116°C)	240°F (116°C)	240°F (116°C)	240°F (116°C)
Maximum Viscosity				
Std. Construction	5, 000 SSU (1100 cP)	5, 000 SSU (1100 cP)	5, 000 SSU (1100 cP)	5, 000 SSU (1100 cP)
High Viscosity Construction	20,000 SSU (4250 cP)	20,000 SSU (4250 cP)	20,000 SSU (4250 cP)	20,000 SSU (4250 cP)
Maximum Differential Pressure	125 psi (8.6 Bar)	125 psi (8.6 Bar)	125 psi (8.6 Bar)	125 psi (8.6 Bar)
Maximum Working Pressure	350 psi (24.1 Bar)	350 psi (24.1 Bar)	350 psi (24.1 Bar)	350 psi (24.1 Bar)

INSTALLATION

NOTICE:

BLACKMER PUMPS MUST ONLY BE INSTALLED IN SYSTEMS DESIGNED BY QUALIFIED ENGINEERING PERSONNEL. SYSTEM DESIGN MUST CONFORM TO ALL APPLICABLE REGULATIONS AND CODES AND PROVIDE WARNING OF ALL SYSTEM HAZARDS.

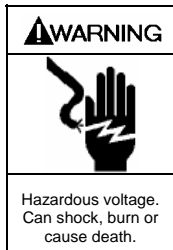

- ⚠ Install ground and wire to local and National Electrical Code requirements.
- ⚠ Install an all-leg disconnect switch near the unit motor.
- ⚠ Disconnect and lockout electrical power before installation or service
- ⚠ Electrical supply **MUST** match motor nameplate specifications.

⚠ Motors equipped with thermal protection automatically disconnect motor electrical circuit when overload exists. Motor can start unexpectedly and without warning.



AN EXTERNAL BYPASS VALVE MUST BE INSTALLED IN THE SYSTEM TO PROTECT THE PUMP FROM EXCESSIVE PRESSURE.

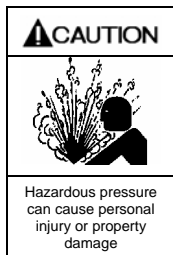

INCORRECT BYPASS VALVE SETTINGS CAN CAUSE PUMP COMPONENT FAILURE, PERSONAL INJURY, AND PROPERTY DAMAGE.

NOTICE:

BLACKMER PROVANE PUMPS ARE NOT FITTED WITH AN INTERNAL PRESSURE RELIEF VALVE THAT BYPASSES THE FLUID BACK TO THE SUCTION SIDE OF THE PUMP.

PRE-INSTALLATION CLEANING

NOTICE:

NEW PUMPS CONTAIN SOME RESIDUAL TEST FLUID AND RUST INHIBITOR. IF NECESSARY, FLUSH PUMP PRIOR TO USE.

Foreign matter entering the pump WILL cause extensive damage. The supply tank and intake piping MUST be cleaned and flushed prior to pump installation and operation.

LOCATION AND PIPING

Pump life and performance can be significantly reduced when installed in an improperly designed system. Before starting the layout and installation of the piping system, review the following suggestions:

1. Locate the pump as near as possible to the source of supply to avoid excessive inlet pipe friction.
2. The inlet line must be at least as large as the intake port on the pump. It should slope downward to the pump, and not contain any upward loops. Eliminate restrictions such as sharp bends; globe valves, unnecessary elbows, and undersized strainers.
3. Install a system bypass valve that returns excess flow to the supply tank or pump inlet piping as appropriate for the pumping system. Insure that the bypass valve pressure setting is appropriate for the pump and system component working pressures.
4. To protect the pump from foreign matter, install a strainer in the inlet line. The strainer should be located at least 24" (0.6m) from the pump, and have a net open area of at least four times the area of the intake piping. Strainers must be cleaned regularly to avoid pump starvation.
5. The intake system must be free of all leaks.
6. When pumping liquids at elevated temperature, make provisions to compensate for expansion and contraction of the pipes, especially when long pipe lines are necessary. Steel pipe expands approximately 3/4" (1.9 cm) per 100 feet (30.49 m) per 100°F (37.8°C) rise in temperature.
7. Expansion joints, placed at least 36" (0.9m) from the pump, will compensate for expansion and contraction of the pipes. Contact the flexible connector/hose manufacturer for required maintenance/care and design assistance in their use.
8. ALL piping and fittings **MUST** be properly supported to prevent any piping loads from being placed on the pump.
9. Install pressure gauges in the NPT ports provided in the pump casing (if equipped) to check pump at start up.
10. Check alignment of pipes to pump to avoid strains which might later cause misalignment. See Figure 1. Unbolt flanges or break union joints. Pipes must not spring away or drop down. After pump has been in operation for a week or two, completely recheck alignment.

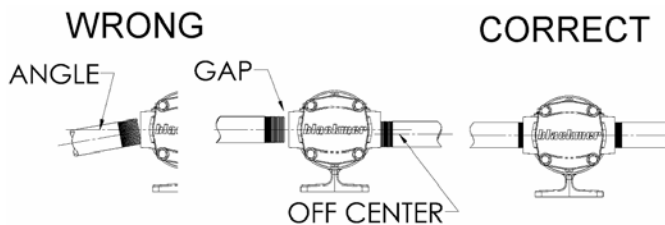

Figure 1

INSTALLATION

PUMP MOUNTING

A solid foundation reduces noise and vibration, and will improve pump performance. On permanent installations it is recommended the pumping unit be secured by anchor bolts as shown in Figure 2. This arrangement allows for slight shifting of position to accommodate alignment with the mounting holes in the base plate.

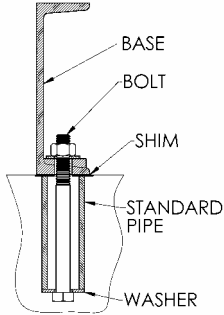

Figure 2 -
Pipe Type Anchor Bolt Box

For new foundations, set the anchor bolts in concrete. When pumps are to be located on existing concrete floors, drill holes into the concrete to hold the anchor bolts.

When installing units built on channel or structural steel type bases, use care to avoid twisting the base out of shape when anchor bolts are tightened. Place shims under the edges of the base prior to tightening of the anchor bolts to prevent distortion.

COUPLING ALIGNMENT

The pump must be directly coupled to a gear reducer and/or driver with a flexible coupling. Both angular and parallel coupling alignment **MUST** be maintained between the pump, gear, motor, etc. in accordance with manufacturer's instructions. See Figure 3.

1. Parallel alignment: The use of a laser alignment tool or dial indicator is preferred. If a laser alignment tool or dial indicator is not available, use a straightedge. Turn both shafts by hand, checking the reading through one complete revolution. Maximum offset must be less than .005" (.127 mm).
2. Angular alignment: Insert a feeler gauge between the coupling halves. Check the spacing at 90° increments around the coupling (four checkpoints). Maximum variation must not exceed .005" (.127 mm). Some laser alignment tools will check angular alignment as well.
3. Replace the coupling guards after setting alignment.

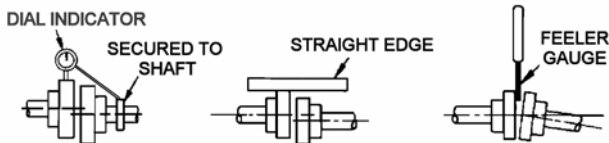
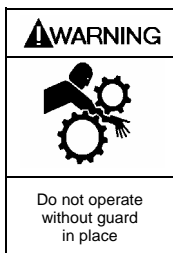

Figure 3 – Alignment Check



OPERATION WITHOUT GUARDS IN PLACE CAN CAUSE SERIOUS PERSONAL INJURY, MAJOR PROPERTY DAMAGE, OR DEATH.

PUMP ROTATION

PV(S)6,8

The pump shaft on these models **always** rotates clockwise when viewed from the driven end.

If the pressure ports on the cylinder are pointing up, the **INTAKE** port will be on the **right**.

If the pressure ports on the cylinder are pointing down, the **INTAKE** port will be on the **left**.

PV(S) 10,15,20,30,40,50,80,100,150,200

A right-hand pump rotates clockwise with the intake on the right side, when viewed from the driven end.

A left-hand pump rotates counterclockwise with the intake on the left side, when viewed from the driven end.

TO REVERSE PUMP FLOW DIRECTION

To reverse **FLOW** direction in a ProVane pump the pump must be disassembled and rebuilt. See *Rotation Options* in the Maintenance section of this manual.

If the rotation of the electric motor driving the pump is incorrect; see the motor manufacturer's instructions to change the rotation of the electric motor to match it to the rotation of the pump.

CHECK VALVES

The use of check valves or foot valves in the supply tank is not recommended with self-priming, positive displacement pumps.

If the possibility of liquid backflow exists when the pump is off, a check valve in the system is recommended because the pump can motor in the reverse rotation and create undue stress on all attached components. Never start a pump when it is rotating in the reverse rotation as the added starting torque can damage the pump and related equipment. If a check valve is used, install it at the pump discharge.

OPERATION

WARNING



Do not operate without guard in place

OPERATION WITHOUT GUARDS IN PLACE CAN CAUSE SERIOUS PERSONAL INJURY, MAJOR PROPERTY DAMAGE, OR DEATH.

WARNING



Hazardous pressure can cause personal injury or property damage

DISCONNECTING FLUID OR PRESSURE CONTAINMENT COMPONENTS DURING PUMP OPERATION CAN CAUSE SERIOUS PERSONAL INJURY, DEATH OR MAJOR PROPERTY DAMAGE

CAUTION



Hazardous pressure can cause personal injury or property damage

FAILURE TO RELIEVE SYSTEM PRESSURE PRIOR TO PERFORMING PUMP SERVICE OR MAINTENANCE CAN CAUSE PERSONAL INJURY OR PROPERTY DAMAGE.

CAUTION



Hazardous pressure can cause personal injury or property damage

PUMPS OPERATING AGAINST A CLOSED VALVE CAN CAUSE SYSTEM FAILURE, PERSONAL INJURY AND PROPERTY DAMAGE

WARNING



Hazardous pressure can cause personal injury or property damage

AN EXTERNAL BYPASS VALVE MUST BE INSTALLED IN THE SYSTEM TO PROTECT THE PUMP FROM EXCESSIVE PRESSURE.

CAUTION



Hazardous pressure can cause personal injury or property damage

INCORRECT BYPASS VALVE SETTINGS CAN CAUSE PUMP COMPONENT FAILURE, PERSONAL INJURY, AND PROPERTY DAMAGE.

PRE-START UP CHECK LIST

1. Check the alignment of the pipes to the pump. Support pipes so that they do not spring away or drop down when pump flanges or union joints are disconnected.
2. Check the entire pumping system to verify that the proper inlet and discharge valves are fully open, and that the drain valves and other auxiliary valves are closed.
3. Install inlet and discharge pressure gauges on the pump in the threaded connections provided. These can be used to check actual suction and discharge conditions after pump start-up.
4. Check the wiring of the motor, and briefly turn on the power to make sure that the pump rotates in the direction of the rotation arrow.

START UP PROCEDURES

NOTICE:

CONSULT THE "GENERAL PUMP TROUBLESHOOTING" SECTION OF THIS MANUAL IF DIFFICULTIES DURING START UP ARE EXPERIENCED.

1. Start the motor. Priming should occur within one minute.
2. Check the suction and discharge pressure gauges to see if the pump is operating within the expected conditions.
3. Check for leakage from the piping and equipment.
4. Check for overheating of the pump, reducer (if equipped), and motor.
5. If possible, check the flow rate.
6. Check the pressure setting of the system bypass valve by slowly restricting a valve in the discharge line and reading the pressure gauge. This pressure should be 20 psi (1.4 bar) higher than the intended operating pressure.

RUNNING THE PUMP IN REVERSE

NOTICE:

WHEN PUMPS ARE OPERATED IN REVERSE A SEPARATE PRESSURE RELIEF VALVE MUST BE INSTALLED TO PROTECT THE PUMP FROM EXCESSIVE PRESSURE.

NOTICE:

PUMP SHOULD BE OPERATED IN REVERSE ROTATION FOR NO MORE THAN 10 MINUTES AND ONLY WHEN A SEPARATE PRESSURE RELIEF VALVE IS INSTALLED TO PROTECT THE PUMP FROM EXCESSIVE PRESSURE.

It may be desirable to run the pump in reverse rotation for system maintenance. The pump will operate satisfactorily in reverse rotation for a LIMITED time, **at a reduced performance level.**

OPERATION

FLUSHING THE PUMP

NOTICE:

IF FLUSHING FLUID IS TO BE LEFT IN THE PUMP FOR AN EXTENDED TIME, IT MUST BE A LUBRICATING, NON-CORROSIVE FLUID. IF A CORROSIVE OR NON-LUBRICATING FLUID IS USED, IT MUST BE FLUSHED FROM THE PUMP IMMEDIATELY.

1. To flush the pump, run the pump with the discharge valve open and the intake valve closed. Bleed air into the pump through the intake gauge plug hole or through a larger auxiliary fitting in the intake piping. Pump air for 30 second intervals to clean out most of the pumpage.
2. Run a system compatible flushing fluid through the pump for one minute to clear out the remainder of the original pumpage. Restrict the valve in the discharge line to build up 10 psi (0.7 bar) to force flushing liquid through the bearing seal chamber.
3. To remove the flushing fluid, follow step 1 above.

NOTICE:

AFTER FLUSHING THE PUMP SOME RESIDUAL FLUID WILL REMAIN IN THE PUMP AND PIPING.

NOTICE:

PROPERLY DISPOSE OF ALL WASTE FLUIDS IN ACCORDANCE WITH THE APPROPRIATE CODES AND REGULATIONS.

PUMP RELIEF VALVE

WARNING



Hazardous pressure can cause personal injury or property damage

AN EXTERNAL BYPASS VALVE **MUST** BE INSTALLED IN THE SYSTEM TO PROTECT THE PUMP FROM EXCESSIVE PRESSURE.

CAUTION



Hazardous pressure can cause personal injury or property damage

INCORRECT BYPASS VALVE SETTINGS CAN CAUSE PUMP COMPONENT FAILURE, PERSONAL INJURY, AND PROPERTY DAMAGE.

NOTICE:

BLACKMER PROVANE PUMPS ARE NOT FITTED WITH AN INTERNAL PRESSURE RELIEF VALVE THAT BYPASSES THE FLUID BACK TO THE SUCTION SIDE OF THE PUMP.

MAINTENANCE:

WARNING



Hazardous machinery can cause serious personal injury.

FAILURE TO DISCONNECT AND LOCKOUT ELECTRICAL POWER OR ENGINE DRIVE BEFORE ATTEMPTING MAINTENANCE CAN CAUSE SEVERE PERSONAL INJURY OR DEATH

WARNING



Hazardous voltage. Can shock, burn or cause death.

FAILURE TO DISCONNECT AND LOCKOUT ELECTRICAL POWER BEFORE ATTEMPTING MAINTENANCE CAN CAUSE SHOCK, BURNS OR DEATH

WARNING



Do not operate without guard in place

OPERATION WITHOUT GUARDS IN PLACE CAN CAUSE SERIOUS PERSONAL INJURY, MAJOR PROPERTY DAMAGE, OR DEATH.

WARNING



Hazardous pressure can cause personal injury or property damage

DISCONNECTING FLUID OR PRESSURE CONTAINMENT COMPONENTS DURING PUMP OPERATION CAN CAUSE SERIOUS PERSONAL INJURY, DEATH OR MAJOR PROPERTY DAMAGE

WARNING



Hazardous or toxic fluids can cause serious injury.

IF PUMPING HAZARDOUS OR TOXIC FLUIDS, SYSTEM MUST BE FLUSHED AND DECONTAMINATED, INSIDE AND OUT, PRIOR TO PERFORMING SERVICE OR MAINTENANCE

WARNING



Hazardous pressure can cause personal injury or property damage

FAILURE TO RELIEVE SYSTEM PRESSURE PRIOR TO PERFORMING PUMP SERVICE OR MAINTENANCE CAN CAUSE PERSONAL INJURY OR PROPERTY DAMAGE.

NOTICE:

MAINTENANCE SHALL BE PERFORMED BY QUALIFIED TECHNICIANS ONLY. FOLLOWING THE APPROPRIATE PROCEDURES AND WARNINGS AS PRESENTED IN THIS MANUAL.

MAINTENANCE

VANE REPLACEMENT (Tandem)

NOTICE:

MAINTENANCE SHALL BE PERFORMED BY QUALIFIED TECHNICIANS ONLY. FOLLOWING THE APPROPRIATE PROCEDURES AND WARNINGS AS PRESENTED IN MANUAL.

For tandem liner models:

1. Flush the pump per instructions in this manual. Drain and relieve pressure from the pump and system as required.
2. Remove the outboard head (non-driven) from the pump according to step 3 in the "Pump Disassembly" section of this manual.
3. Remove the outboard rotor (13D) vanes (14) & pushrods (77) by removing the socket cap-screws (13C) Set aside for reassembly.
4. Remove the outboard liner (41A) and rotating disc (13E) to access the inboard vanes.
5. Turn the shaft by hand until a worn vane comes to the top (12 o'clock) position of the rotor. Remove the vane.
6. Install a new vane, ensuring that the rounded edge is UP, and the relief grooves are facing towards the direction of rotation. See Figure 7.
7. Repeat steps 5 and 6 until all inboard vanes have been replaced. This method of vane installation ensures the push rods do not fall out of their rotor slots.
8. Install the rotating disc (13E) into the recess of the inboard liner. Positioning it over the threaded holes for the outboard rotor.
9. Install the outboard liner over the disc aligning "pumping chamber" opposite of the inboard Liner.
10. Install the pushrods (77) & 3 vanes (14) in the outboard rotor (13D). Position at the bottom so pushrods are held in place. Place in the pump aligning the holes for the socket cap-screws with the holes in the rotating disc and Inboard liner.
11. Install the socket cap-screws (13C) torque per table 1.
12. Install new vanes in the top 3 vane slots, ensuring that the rounded edge is UP, and the relief grooves are facing towards the direction of rotation. See Figure 7.
13. Reassemble the pump according to the "Pump Assembly." section of this manual.
3. Remove the head cap screws (21A). Gently pry the head away from the casing using two large screwdrivers. The head O-ring should come off with the head assembly.
4. Loosen the set screws of the bearing 1-2 full turns with the appropriately sized hex key wrench. Lightly tap the end of the exposed shaft with a hard wood drift and a hammer until the bearing shaft sleeve releases the shaft.
5. **On 6A & 8A models:** to remove locknut and lock washer (24A and 24B):
 - a. Bend up the engaged lock washer tang and rotate the locknut counterclockwise to remove it from the shaft.
 - b. Slide the lock washer off the shaft. Inspect the lock washer for damage and replace as required.
6. Remove the rotor and shaft (13) from the casing. While one hand is pushing the shaft, place the other hand underneath the rotor to prevent the vanes (14) and pushrods (77) from falling out. As the rotor & shaft are removed further, carefully support the shaft so it does not drop and damage the sleeve bearing or finished surfaces of the shaft or the rotating seal face as it is removed. Carefully set the rotor and shaft aside for future vane replacement and reassembly.
7. **On tandem liner models PV(S) 80,100,150,200:** The outboard liner will need to be removed before the rotor and shaft assembly due to the rotating disc. See Tandem Vane replacement steps 3-4.
8. To remove the casing or cylinder. Lay the pump on end with the bearing housing facing upward and remove the 4 cap screws (21A). Lift off the bearing housing and remove the casing O-ring (71).
9. **On stainless pumps equipped with an inboard head** Remove the inboard head (20) from the bearing housing. Remove the casing O-ring (71) from between the inboard head and the casing or cylinder.
10. The mechanical seal & spring assembly should come out with the shaft. The stationary seat and stationary seal ring need to be removed from the seal cover (126).
 - a. To remove the seal cover remove the hex nuts (127A) & cap-screws (127) holding it in place on both sides of the bearing housing.
 - b. Slowly pry the seal cover away from the bearing housing until it can be removed. Remove and discard the seal cover O-ring (51).
11. **On Stainless Steel** models where the seal cover is attached to the inboard head (22). Remove the mechanical seal by removing the 4 cap screws (21A) securing it to the inboard head.
12. Carefully pry the stationary seal elements (153A) from the seal cover (126). Be sure not to scratch the seal face or damage the elastomer seal seat.
13. If necessary, remove the liner (41) from the casing (12) by tapping around the outside diameter of the liner with a hard wood drift and a hammer until it is driven from the casing.
14. Remove the ball bearing adjuster (188) by loosening the sets screws (189) and turning it counter clockwise with a strap wrench or spanner wrench.

PUMP DISASSEMBLY

NOTICE:

FOLLOW ALL HAZARD WARNINGS AND INSTRUCTIONS PROVIDED IN THE "MAINTENANCE" SECTION OF THIS MANUAL.

NOTE: The numbers in parentheses following individual parts indicate reference numbers on the Pump Parts List.

1. Flush the pump per instructions in this manual. Drain and relieve pressure from the pump and system as required.
2. Starting on the inboard (driven) end of the pump, clean the pump shaft thoroughly, making sure the shaft is free of nicks and burrs. This will prevent damage to the mechanical seal when removed.

MAINTENANCE

15. If necessary for replacement, remove the ball bearing (24C) from the bearing adjuster. Turn the bearing adjuster so the threaded side is up. Using an appropriately sized arbor press remove the bearing (24C) from the bearing adjuster. Discard old bearing and replace with new one. See step 2 of "PUMP ASSEMBLY"
16. If the sleeve bearing is worn or damaged:
 - a. **Ductile iron models:** Remove the sleeve bearing (24) from the bearing housing (57) using an appropriately sized arbor press.
 - b. **Stainless steel models:** The inboard head & bearing assembly (drive housing & bearing assembly on PVS6A and PVS8A) must be replaced.
17. **Only disassemble rotor & shaft if necessary for part replacement.** To disassemble the rotor (13B) and shaft (13A) by removing the three cap-screws (13C). On tandem pump models, first remove the outboard set of socket cap screws (13C), the outboard rotor (13D) and the rotating disc (13E). See figures 8 & 9

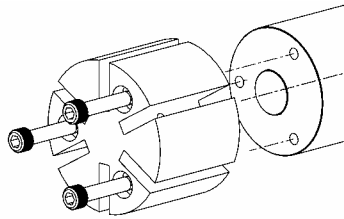

Figure 8 Single Rotor

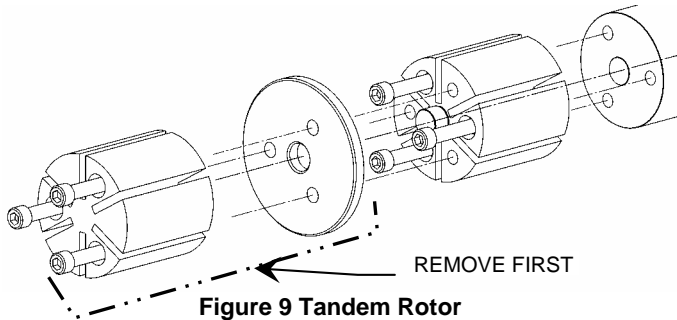

Figure 9 Tandem Rotor

PARTS REPLACEMENT

1. If any of the O-rings have been removed or disturbed during disassembly, they need to be replaced with new O-rings.
NOTE: PTFE O-rings should be heated in hot water to aid installation.
2. Excessive or continuous leakage from around the seal housing or in the bearing housing may be an indication of a damaged mechanical seal. If a mechanical seal has been leaking, it is recommended the entire seal be replaced. Refer to "General Pump Troubleshooting" for possible causes of seal leakage.
3. Inspect bearings for wear and replace as necessary.

PUMP ASSEMBLY

Before reassembling the pump, inspect all component parts for wear or damage, and replace as required. Wash out the bearing/seal recess of the head and remove any burrs or nicks from the rotor and shaft.

Reassemble the BEARING Components first:

To aid in the replacement of the **sleeve bearing** the creation and use of a tool similar to the one shown in Figure 10 may be useful.

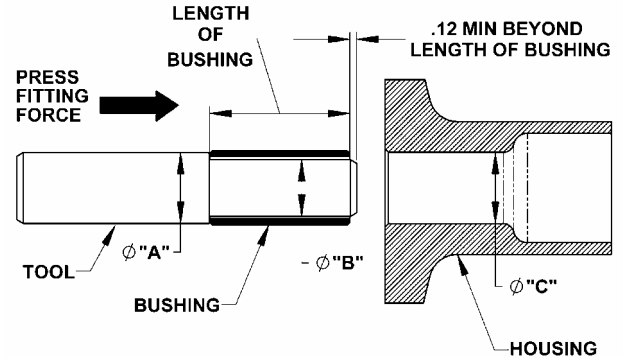

Figure 10

Bushing Part Number	Bearing Bore Dia. "C"	Tool Dim "A"	Tool Dim "B"
166805	1.26 IN. (32mm)	2.05 IN. (52 mm)	1.25 IN. (31.75 mm)
166205	1.97 IN. (50 mm)	2.76 IN. (70 mm)	1.96 IN. (49.75 mm)
165805	2.56 IN. (65 mm)	3.35 IN. (85 mm)	2.55 IN. (64.75 mm)
165806	3.15 IN. (80 mm)	3.94 IN. (100 mm)	3.14 IN. (79.75 mm)

1. Inspect the sleeve bearing (24) for wear or damage and replace as required.
To replace sleeve bearing: (**ductile iron models only**)
 - a. Using an appropriately sized arbor press, remove the old bearing (24) from the bearing housing (57).
 - b. To aid installation and prevent bearing damage. Coat the bearing (24) with grease and place it on the face of the bearing housing (57).
 - c. Using an arbor press, press the bearing (24) into the housing (57) in one continuous motion, until it is **flush** with the face of the bearing housing.**NOTE:** Ensure the bearing does not become misaligned during the pressing motion.
2. Inspect the ball bearing (24C) for wear or damage and replace as required.
To replace ball bearing:
 - a. Using an appropriately sized arbor press, remove the old bearing (24C) from the bearing adjuster (188). Discard the old bearing after removal.
 - b. To aid installation and prevent bearing damage. Coat the bearing with grease and place it on the face of the bearing adjuster (188)
 - c. Using an arbor press, press the OD of the bearing into the bearing adjuster in one continuous motion, until it is seated in the bearing adjuster.
3. Screw the bearing adjuster (188) to the bearing housing (57) until they are flush. Be sure that the 2 setscrews (189) are not interfering with the flush fit of the bearing adjuster to the bearing housing.

MAINTENANCE

NOTE: On those pumps that are fitted with commercial Mechanical Seals refer to the seal manufacturer's instructions for removal and replacement.

4. MECHANICAL SEAL

Installing the Stationary Seat

- a. Apply a small amount of lubricant in the seal access of the seal cover (126). The bearing adjuster (188) on PV6-8 Models
 - b. Install a new stationary seal-ring and stationary seat. Clean the polished face with a clean tissue and alcohol..
5. Install a new O-ring (51) in to the seal cover (126)
 6. Lubricate the O-ring seal area on the bearing housing (57) with a light coating of oil. Insert the seal cover (126) into the bearing housing. For those pumps equipped with an inboard head (20) lubricate the O-ring seal area and insert the seal cover (126) onto the inboard head.
 7. Secure the seal cover to the bearing housing (57) by installing the cap-screws (127) & hex nuts (127A) holding it in place on both sides of the bearing housing. Torque per table 1.
 8. On those pumps where the seal cover (126) secures to the inboard head (20). Secure the seal cover to the inboard head by installing the 4 cap-screws (21A). Torque per table 1.
 9. **On stainless pumps equipped with an inboard head,** (20) install the head in the bearing housing (57)
 10. Head O-ring installation
 - a. Install a new O-ring (71) over the dowel of the Bearing housing (57).
 - b. For those pumps with an inboard head (20) install the O-ring over the dowel of the inboard head.
 11. Reassemble the casing or cylinder to the bearing housing. Positioning it for the desired pump rotation. Install cap screws (21A) through the bearing housing into the casing. Torque per Table 1.

Liner Intake & Discharge Identification

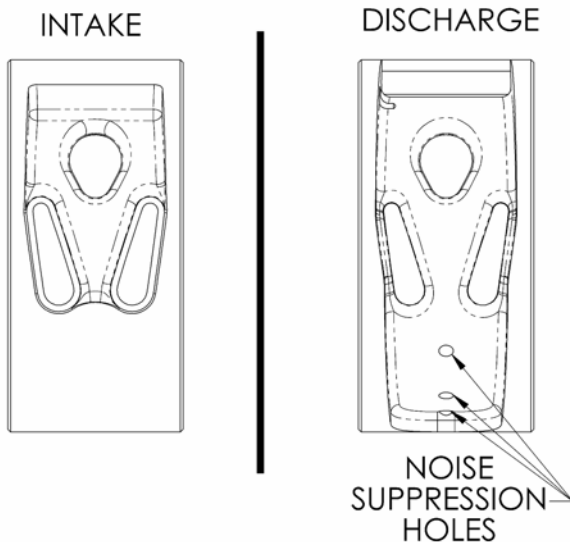

FLOW DIRECTION OPTIONS

For Cylinders: PV(S) 6,8:

For the pump to operate with the INTAKE port on the **RIGHT** as viewed from the driven end of the pump, position the cylinder with the pressure ports pointing up in relation to the feet. The pump will operate in a **CLOCKWISE ROTATION**.

For the pump to operate with the INTAKE port on the **LEFT** as viewed from the driven end of the pump, position the cylinder with the pressure ports pointing down in relation to the feet. The pump will operate in a **CLOCKWISE ROTATION**.

NOTE NO vane or rotational changes required to reverse flow direction for PV(S) 6,8

For Single Liner Casings: PV(S) 10,15,20,30,40,50:

For a **CLOCKWISE** rotation pump; install the liner in the casing with the Inlet to the **right**. As viewed from the driven end of the pump

For a **COUNTERCLOCKWISE** rotation pump; install the liner in the casing with the Inlet to the **left**. As viewed from the driven end of the pump

For Tandem Liner Casings: PV(S) 80,100,150,200: Install the inboard liner.

For a **CLOCKWISE** rotation pump, install the pump casing, then install liner (41A) with the inlet in the 6 o'clock position.

For a **COUNTERCLOCKWISE** rotation pump, install the pump casing, then install liner (41B) with the inlet in the 12 o'clock position.

Note: Match marks on the liners must align and be positioned toward the pump inlet.

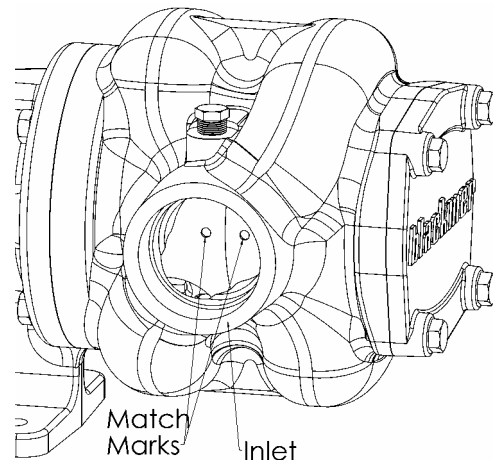

MAINTENANCE

12. Mechanical Seal Rotating Assembly

- Apply a small amount of Flowserve Pac-Ease™ or equivalent lubricant on the shaft between the shaft end and the rotor.
- Slide the seal rotating assembly (153B) over the shaft with the rotating face away from the rotor until contact is made with the large diameter of the shaft.
- Align the rotating assembly with the seal jacket polished face outward. Clean the polished face with a clean tissue and alcohol.

13. Assemble Rotor and Shaft.

If rotor and shaft are disassembled.

- Loosely assemble rotor (13B) on to shaft (13A) securing with socket cap screws (13C).
DO NOT damage the OD surface finish of the rotor and shaft.
- Secure a piece of steel sized to fit the width and length of a vane slot in a vise or other holding device. Place the loosely assembled rotor and shaft on to the piece of steel in one of the vane slots; completely filling the entire vane slot.
- Hold the assembly securely without damaging the OD of the rotor or shaft.
- Tighten the socket cap screws (13C). Torque per Table 1.

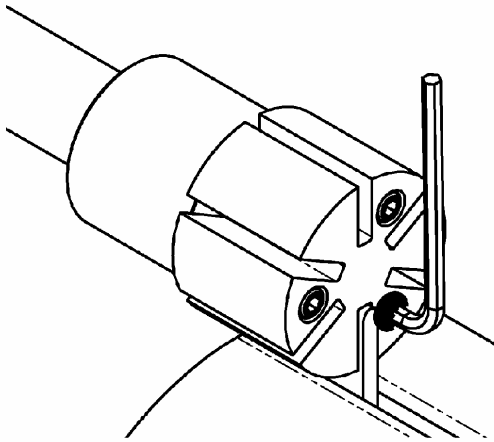

Figure 12 – Rotor / Shaft Assembly Torque

14. PUSHROD INSTALLATION

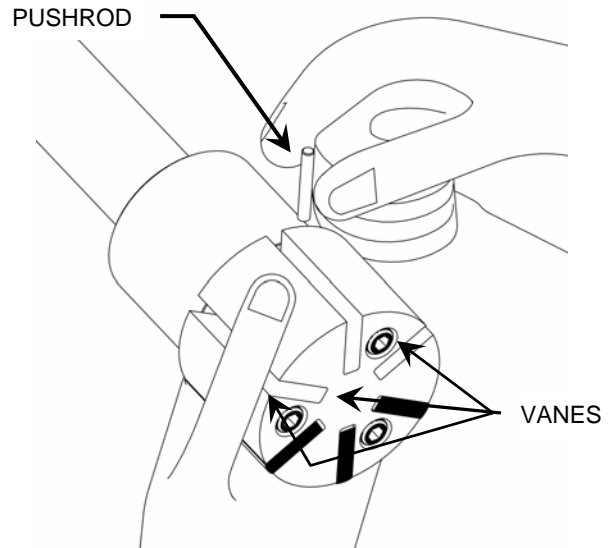

Figure 13 – Pushrod Installation

- Insert the vanes into the bottom three rotor slots with the relief grooves facing in the direction of pump rotation, and rounded edges outward. See Figures 7 & 13
- Hold the three bottom vanes in place while inserting the three push rods (77). See Figure 13
- After the bottom vanes and push rods are installed, carefully insert the driven end of rotor and shaft into the casing.
- Install the rotor and shaft assembly (13) with the rotating seal elements into the bearing housing from the sleeve bearing end putting the shaft through the ball bearing and lightly securing it with the set screws on the ball bearing.
- Install the new vanes by rotating the shaft until an empty vane slot is in the 12 o'clock position, ensuring that the rounded edge is UP, and the relief grooves are facing towards the direction of rotation. See Figure 7.
Repeat until all vanes have been installed. This method of vane installation ensures the push rods do not fall out of their rotor slots.
- On tandem pumps PV(S) 80,100,150,200:**
 - Install the rotating disc, outboard rotor, and liner AFTER the shaft is in place in the pump and the inboard vanes are installed.
 - Install the rotating disc (13E) into the recess of the inboard liner. Positioning it so the threaded holes are exposed on the inboard rotor.
 - Install the outboard liner over the disc positioning it to align to the pin on the outboard head.
 - Install the pushrods (77) & 3 vanes (14) in the outboard rotor (13D) position at the bottom so pushrods are held in place. Place in the pump aligning the holes for the socket cap-screws with the holes in the rotating disc and inboard rotor.
 - Install the socket cap screws (13C). Torque per Table 1.
 - Install new vanes in the top 3 vane slots, ensuring that the rounded edge is UP, and the relief grooves are facing towards the direction of rotation. See Figure 7.

MAINTENANCE

21. LOCKNUT ADJUSTMENT PV6A & PV8A

It is important that the bearing locknut (24A) and lock washer (24B) be installed and adjusted properly. Over tightening the locknut can cause bearing failure or a broken lock washer tang. A loose locknut will allow the rotor to shift within the pump, causing wear. See Figure 14.

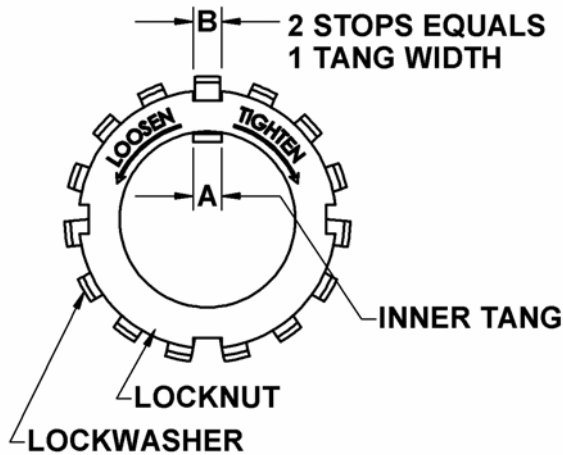

Figure 14 – Locknut Assembly

- On the end of the pump shaft, install a lock washer (24B) with the tangs facing outward, followed by a locknut (24A) with the tapered end inward. Ensure the inner tang "A" of the lock washer is located in the slot in the shaft threads, bending it slightly, if necessary.
- Tighten the locknut to ensure that the bearing is bottomed in the recess. **DO NOT** over tighten and bend or shear the lock washer inner tang.

Bearing Adjustment for All Models

To properly adjust the bearing the head **MUST** be installed.

- Install a new head O-ring (72) in the groove on the dowel of the head. Lay the O-ring flat and start in on one side of the groove, stretching ahead with the fingers, as shown in Figure 15.

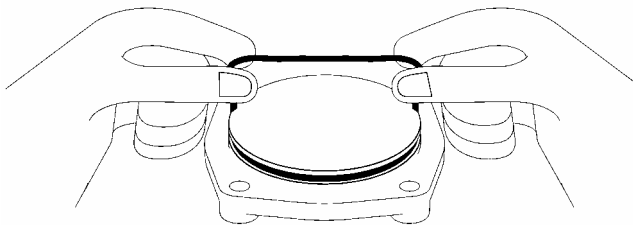

Figure 15 – Head O-ring Installation

- Carefully install the head (23) into the casing or cylinder. Install and tighten four head cap screws (21A). Torque per table 1.
- Back off the bearing adjuster (188) 1-2 turns to allow for setting the end clearance.
- For PV(S) 10,15,20,30,40,50,80,100,150,200**
Secure the ball bearing (24C) to the shaft by uniformly tightening the setscrews on the bearing. Bearing **MUST** be tightened with allen wrench per Torque Table 1 or the special self indicating torque tool.

- Turn the bearing adjuster (188) counterclockwise, as viewed from the driven end of the pump, until the shaft is snug and no longer turns. Mark a line across the bearing adjuster and drive housing (57).
- Turn the bearing adjuster (188) clockwise, as viewed from the driven end of the pump the distance prescribed per table 2. Measurement to be taken on outside of drive housing (57).

Table 2

Pump size	Distance on OD of Drive Housing (57)
PV(S) 6,8	3/4" 1.9 cm
PV(S) 10,15	11/16" 1.75 cm
PV(S) 20-100	3/4" 1.9 cm
PV(S) 150,200	3/4" 1.9 cm

- Tighten the bearing adjuster setscrew (189) and torque per Table 1.
*Note, some pumps are equipped with dual setscrews located in bearing adjuster and some are equipped with a single setscrew located in drive housing. Use appropriate torque as specified.
- Reinstall coupling, shaft key, and coupling guards.
- Refer to "Pre-Start Up Check List" and "Start Up Procedures" sections of this manual prior to restarting pump operation.

GENERAL PUMP TROUBLESHOOTING

NOTICE:

MAINTENANCE SHALL BE PERFORMED BY QUALIFIED TECHNICIANS ONLY, FOLLOWING THE APPROPRIATE PROCEDURES AND WARNINGS AS PRESENTED IN THIS MANUAL.

LEAKAGE

Location

Between the head & casing

Probable Cause/Corrective Action

Damaged head O-ring: Inspect and replace if necessary.

Burrs/dirt in head O-ring groove or cylinder: File and clean as necessary.

Around the shaft

New Mechanical Seals: New seals may leak slightly at start up, but should seal up shortly thereafter.

Damaged mechanical seals: Check for damaged O-rings or cracked, scratched or worn seal faces

SHAFT BINDING

Probable Cause

Burrs, dirt or foreign particles on the heads or discs.

Corrective Action

During assembly, both heads and discs must be clean and smooth. File any burrs or rough spots, and wipe the discs with a clean cloth and alcohol to remove any dirt or foreign particles.

Improper bearing adjustment.

Bearings must be adjusted properly to center the rotor and shaft between the head & bearing housing. Refer to the "Pump assembly " section of this manual.

Contaminated mechanical seal faces.

Any trace of grease or dirt on the seal faces will prevent the faces from mating properly, causing the rotor and shaft to bind or turn hard. Use a tissue paper & alcohol to clean the seal faces. NOTE: Apply a light oil or suitable lubricant to bronze seal faces only.

OTHER POSSIBLE CAUSES OF SHAFT BINDING:

- Foreign particles on rotor, liner or vanes.
- Damaged vanes or rotor.

- Bent push rods.
 - Liquids that "set up" when inactive.
-

OVERHEATING

Probable Cause

A pump can overheat if it runs in bypass mode too long or if the bypass loop is too short

Corrective Action

OTHER POSSIBLE CAUSES OF OVERHEATING:

- Improper system bypass valve adjustment
 - Plugged discharge line.
 - Closed valve.
-

LOW DELIVERY RATE

Probable Cause

Bypass valve setting too low, causing the liquid to bypass.

Corrective Action

Set the bypass valve 20 psi (1.4 bar) higher than the differential pressure.

OTHER POSSIBLE CAUSES OF A LOW DELIVERY RATE:

- Restriction in the suction line.
- Resistance in the discharge line.
- Air leaks in the suction line.
- Damaged or worn pump parts.
- Pump speed too low or too high.

- Bypass valve leaking.
- Bypass valve sticking open, or not properly seating.
- Dirty strainer.
- Liner installed backwards
- Pump running in reverse

GENERAL PUMP TROUBLESHOOTING

EXCESSIVE NOISE AND VIBRATION

Probable Cause

Cavitation or vaporization of the liquid resulting from excessive vacuum on the pump due to starved suction.

Entrained air or vapors in the pump.

Pump speeds exceed the recommended maximum.

Liner Installed Backwards

Continual or long term bypassing of liquid through system bypass valve.

Corrective Action

Check for:

- Inlet piping too long or too small in diameter.
- Strainer plugged or dirty.
- Undersized or restrictive fittings, such as globe valves or partially closed valves.
- Excessive amount of elbows.
- Suction lift too great.
- Pump speed too high for the viscosity of the liquid being pumped.

Check pipe joints for leakage of air. Sometimes when recirculating liquid in a tank, the returning liquid falling through the air carries air down into the tank, which eventually gets back into the pump.

Check the recommended RPM for your specific application.

The word "INTAKE", which is cast on the liner MUST be towards the intake side of the pump

Check for restriction in the discharge line, or an improper bypass valve adjustment

OTHER POSSIBLE CAUSES OF NOISE AND VIBRATION:

- Excessively worn vanes
- Bearing Worn or Damaged.
- Loose or improperly installed piping.
- Misalignment of pump and driver.
- Pump base not properly mounted.

POOR OR NO PRIMING

Probable Cause

- Air leaks in the suction line.
- Restriction in the suction line.
- Damaged or worn pump parts.
- Too much lift for the vapor pressure of the fluid.
- A dirty or clogged strainer.
- Worn vanes.
- Suction Valve Closed.
- Incorrect pump rotation
- Bypass Valve partially open, valve not seating properly.

DAMAGED VANES

Probable Cause

- Foreign objects entering the pump.
- Running the pump dry for extended periods of time.
- Cavitation.
- Viscosity too high for the vanes and /or the pump speed.
- Incompatibility with the liquids pumped.
- Excessive heat.
- Worn or bent push rods, or worn push rod holes.
- Settled or solidified material in the pump at start-up.
- Hydraulic hammer - pressure spikes.
- Vanes installed incorrectly (see "Vane Replacement").

BROKEN SHAFT

Probable Cause

- Foreign objects entering the pump.
- Viscosity too high for the pump speed.
- Bypass valve not opening.
- Hydraulic hammer - pressure spikes.
- Pump/driver, driveline/drive shaft misalignment.
- Excessively worn vanes or vane slots.
- Settled or solidified material in the pump at start-up.

SEAL LEAKAGE

Probable Cause

- O-rings not compatible with the liquids pumped.
- O-rings nicked, cut or twisted.
- Shaft at seal area damaged, worn or dirty.
- Excessive cavitation.
- Mechanical seal faces cracked, scratched, pitted or dirty.
- Ball bearings worn.

MOTOR OVERLOAD

Probable Cause

- Horsepower of motor not sufficient for application
- Improper wire size / wiring and/or voltage to motor.
- Misalignment in pump drive system.
- Excessive viscosity, pressure or speed.
- Faulty or worn bearings.
- Rotor rubbing against head or liner.
- Dirty mechanical seal faces.

NOTES

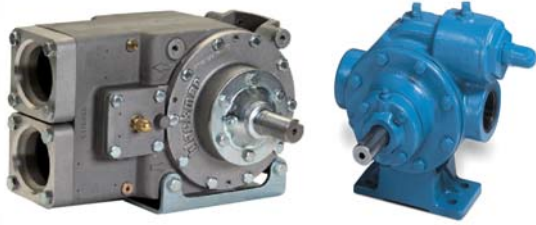

Sliding Vane Pumps: 5 to 2200 GPM
Refined Fuels, Liquefied Gases, Process,
Transport, Marine

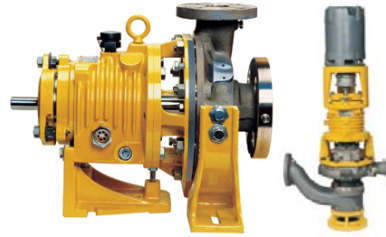

System One Centrifugal Pumps
10 to 7500 GPM
Process, Marine



C-Series Eccentric Disc Pumps
1 to 150 GPM
Shear Sensitive, Food, Process



Abaque Peristaltic Hose Pumps
0.5 to 220 GPM
High Lift, Solids, Abrasives



Rotary Vane and Screw Compressors
Dry Bulk Unloading



Reciprocating Gas Compressors
Liquefied Gas Transfer, Boosting, Vapor Recovery



Hydraulic Coolers
Complete Packages



Magnetic Drive Pumps
Iron and Stainless, 14 to 333 GPM



Hand Operated Pumps
Dispensing, Transfer, In-line



Accessories
Gear Reducers, Bypass Valves, Strainers

Visit www.blackmer.com for complete information on all Blackmer products



1809 Century Avenue, Grand Rapids, Michigan 49503-1530 U.S.A.
Telephone: (616) 241-1611 • Fax: (616) 241-3752
E-mail: blackmer@blackmer.com • Internet Address: www.blackmer.com